

MANHOLE FRAME & COVER

SEE MANHOLE
EFFLUENT &
INFLUENT DETAIL

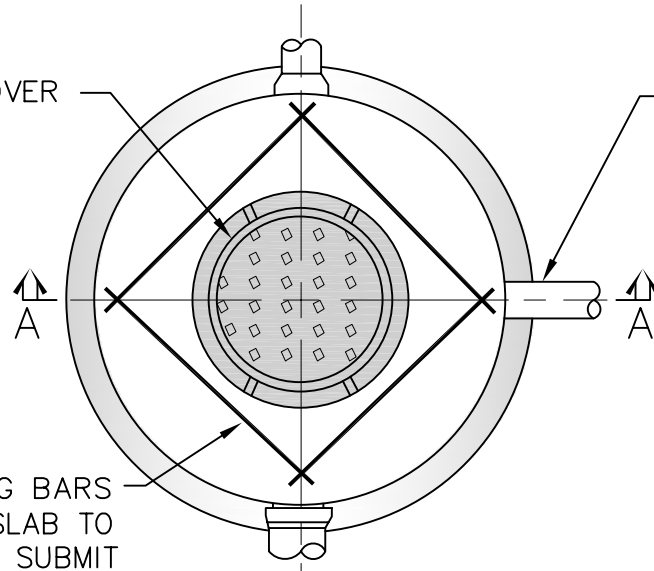

ADDITIONAL REINFORCING BARS
REQUIRED AT OPENING. SLAB TO
TO BE TRAFFIC BEARING. SUBMIT
SHOP DRAWING FOR APPROVAL

PLAN VIEW

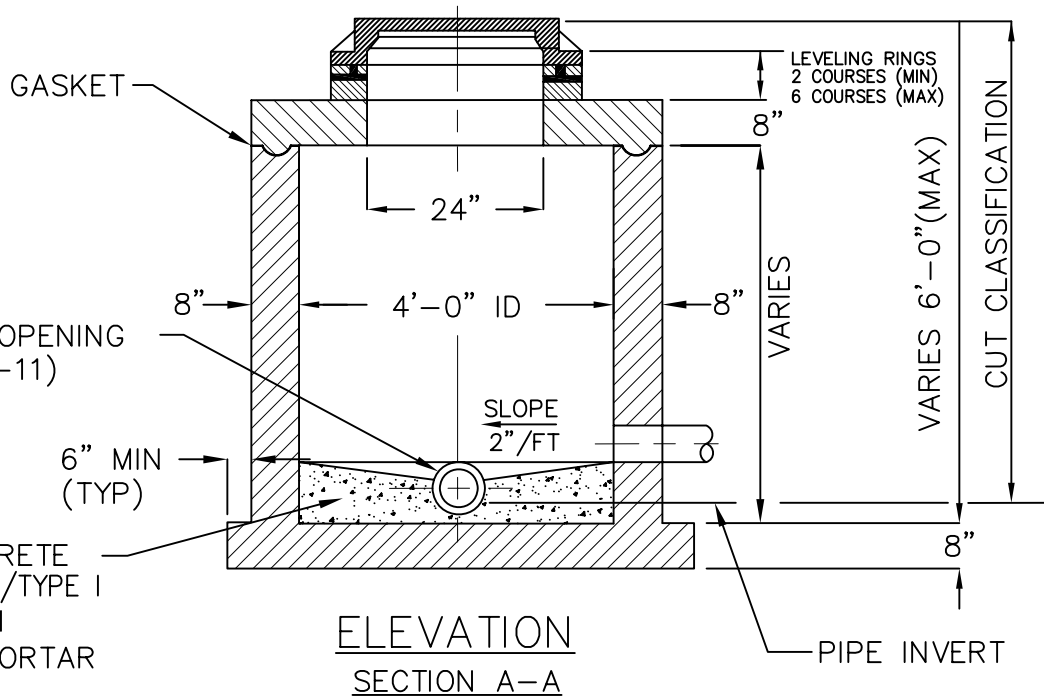

SEE PIPE OPENING
DETAIL (S-11)

FILL CONCRETE
OR BRICK W/TYPE I
OR TYPE II
CEMENT MORTAR

ELEVATION
SECTION A-A

TO BE USED WHEN CUT CLASSIFICATION IS 6'-0" OR LESS

-ART-

NOTES

1. SEE MANHOLE NOTES ON DRAWING NO. S-5
2. SEE STANDARD MANHOLE CASTING DRAWING NO. S-4
3. SEE PIPE OPENING DETAIL DRAWING NO. S-11
4. SEE MANHOLE EFFLUENT & INFLUENT DETAIL DRAWING NO. S-12

INDIAN RIVER COUNTY
DEPARTMENT OF
UTILITIES SERVICES



MANHOLE
SLAB TOP

MARCH 2014

DRAWING
NO.
S-7